

Series LFII Residential Pendent Sprinklers 4.9 K-factor

General Description

The Series LFII (TY2234) Residential Pendent Sprinklers are decorative, fast response, frangible bulb sprinklers designed for use in residential occupancies such as homes, apartments, dormitories, and hotels. When aesthetics and optimized flow characteristics are the major consideration, the Series LFII (TY2234) should be the first choice.

The Series LFII are to be used in wet pipe residential sprinkler systems for one- and two-family dwellings and mobile homes per NFPA 13D; wet pipe residential sprinkler systems for residential occupancies up to and including four stories in height per NFPA 13R; or, wet pipe sprinkler systems for the residential portions of any occupancy per NFPA 13.

The Series LFII (TY2234) has a 4.9 (70,6) K-factor that provides the required residential flow rates at reduced pressures, enabling smaller pipe sizes and water supply requirements.

The recessed version of the Series LFII (TY2234) is intended for use in areas with finished ceilings. It employs a two-piece Style 20 Recessed Escutcheon. The Recessed Escutcheon provides 1/4 inch (6,4 mm) of recessed adjustment or up to 1/2 inch (12,7 mm) of total adjustment from the flush ceiling position. The adjustment provided by the Recessed Escutcheon reduces the accuracy to which the pipe nipples to the sprinklers must be cut.

The Series LFII (TY2234) has been designed with heat sensitivity and water distribution characteristics proven to help in the control of residential fires and to improve the chance for occupants to escape or be evacuated.

WARNINGS

The Series LFII (TY2234) Residential Pendent Sprinklers described herein must be installed and maintained in compliance with this document, as well as with the applicable standards of the National Fire Protection Association, in addition to the standards of any other authorities having jurisdiction. Failure to do so may impair the integrity of these devices.

The owner is responsible for maintaining their fire protection system and devices in proper operating condition. The installing contractor or sprinkler manufacturer should be contacted relative to any questions.

Sprinkler/Model Identification Number

SIN TY2234

Technical Data

Approvals:
UL and C-UL Listed.

Maximum Working Pressure:
175 psi (12,1 bar)

Discharge Coefficient:
K = 4.9 GPM/psi^{1/2} (70,6 LPM/bar^{1/2})

Temperature Rating:
155°F/68°C or 175°F/79°C

Finishes:
White Polyester Coated,
Chrome Plated, or Natural Brass

Physical Characteristics:
Frame Brass
Button Bronze
Sealing Assembly
. Beryllium Nickel w/Teflon†
Bulb 3 mm dia. Glass
Compression Screw Bronze



Deflector Bronze
Ejection Spring Stainless Steel

†DuPont Registered Trademark

Operation

The glass Bulb contains a fluid that expands when exposed to heat. When the rated temperature is reached, the fluid expands sufficiently to shatter the glass Bulb allowing the sprinkler to activate and flow water.

Maximum Coverage Area ^(a) Ft. x Ft. (m x m)	Maximum Spacing Ft. (m)	Minimum Flow ^(b) and Residual Pressure For Horizontal Ceiling (Max. 2 Inch Rise for 12 Inch Run)	Minimum Flow ^(b) and Residual Pressure For Sloped Ceiling (Greater Than 2 Inch Rise Up To Max. 4 Inch Rise for 12 Inch Run)		Minimum Flow ^(b) and Residual Pressure For Sloped Ceiling (Greater Than 4 Inch Rise Up To Max. 8 Inch Rise for 12 Inch Run)	
		155°F/68°C or 175°F/79°C	155°F/68°C	175°F/79°C	155°F/68°C	175°F/79°C
12 x 12 (3,7 x 3,7)	12 (3,7)	13 GPM (49,2 LPM) 7.0 psi (0,48 bar)	13 GPM (49,2 LPM) 7.0 psi (0,48 bar)	17 GPM (64,3 LPM) 12.0 psi (0,83 bar)	13 GPM (49,2 LPM) 7.0 psi (0,48 bar)	18 GPM (68,1 LPM) 13.5 psi (0,93 bar)
14 x 14 (4,3 x 4,3)	14 (4,3)	13 GPM (49,2 LPM) 7.0 psi (0,48 bar)	13 GPM (49,2 LPM) 7.0 psi (0,48 bar)	17 GPM (64,3 LPM) 12.0 psi (0,83 bar)	13 GPM (49,2 LPM) 7.0 psi (0,48 bar)	18 GPM (68,1 LPM) 13.5 psi (0,93 bar)
16 x 16 (4,9 x 4,9)	16 (4,9)	13 GPM (49,2 LPM) 7.0 psi (0,48 bar)	13 GPM (49,2 LPM) 7.0 psi (0,48 bar)	17 GPM (64,3 LPM) 12.0 psi (0,83 bar)	13 GPM (49,2 LPM) 7.0 psi (0,48 bar)	18 GPM (68,1 LPM) 13.5 psi (0,93 bar)
18 x 18 (5,5 x 5,5)	18 (5,5)	17 GPM (64,3 LPM) 12.0 psi (0,83 bar)	17 GPM (64,3 LPM) 12.0 psi (0,83 bar)	17 GPM (64,3 LPM) 12.0 psi (0,83 bar)	17 GPM (64,3 LPM) 12.0 psi (0,83 bar)	23 GPM (87,1 LPM) 22.0 psi (1,52 bar)
20 x 20 (6,1 x 6,1)	20 (6,1)	20 GPM (75,7 LPM) 16.7 psi (1,15 bar)	20 GPM (75,7 LPM) 16.7 psi (1,15 bar)	20 GPM (75,7 LPM) 16.7 psi (1,15 bar)	21 GPM (79,5 LPM) 18.4 psi (1,27 bar)	N/A

(a) For coverage area dimensions less than or between those indicated, it is necessary to use the minimum required flow for the next highest coverage area for which hydraulic design criteria are stated.

(b) Requirement is based on minimum flow in GPM (LPM) from each sprinkler. The associated residual pressures are calculated using the nominal K-factor. Refer to Hydraulic Design Criteria Section for details.

TABLE A
NFPA 13D AND NFPA 13R HYDRAULIC DESIGN CRITERIA FOR THE SERIES LFII (TY2234)
RESIDENTIAL PENDENT AND RECESSED PENDENT SPRINKLERS

Design Criteria

The Series LFII (TY2234) Residential Pendent Sprinklers are UL and C-UL Listed for installation in accordance with the following criteria.

NOTE

When conditions exist that are outside the scope of the provided criteria, refer to the Residential Sprinkler Design Guide TFP490 for the manufacturer's recommendations that may be acceptable to the local Authority having Jurisdiction.

System Type. Only wet pipe systems may be utilized.

Hydraulic Design. The minimum required sprinkler flow rate for systems designed to NFPA 13D or NFPA 13R are given in Table A as a function of temperature rating and the maximum allowable coverage areas. The sprinkler flow rate is the minimum required discharge from each of the total number of "design sprinklers" as specified in NFPA 13D or NFPA 13R.

For systems designed to NFPA 13, the number of design sprinklers is to be the four most hydraulically demanding sprinklers. The minimum required discharge from each of the four sprinklers is to be the greater of the following:

- The flow rates given in Table A for NFPA 13D and 13R as a function of

temperature rating and the maximum allowable coverage area.

- A minimum discharge of 0.1 gpm/sq. ft. over the "design area" comprised of the four most hydraulically demanding sprinklers for the actual coverage areas being protected by the four sprinklers.

Obstruction To Water Distribution. Locations of sprinklers are to be in accordance with the obstruction rules of NFPA 13 for residential sprinklers.

Operational Sensitivity. The sprinklers are to be installed with a deflector to ceiling distance of 1-3/8 to 4 inches or in the recessed position using only the Style 20 Recessed Escutcheon as shown in Figure 2.

NOTE

So as to help avoid obstructions to water distribution, a maximum 12 inch deflector-to-ceiling distance is permitted for NFPA 13D and NFPA 13R applications where the sprinklers are located in closets.

Sprinkler Spacing. The minimum spacing between sprinklers is 8 feet (2,4 m). The maximum spacing between sprinklers cannot exceed the length of the coverage area (Ref. Table A) being hydraulically calculated (e.g., maximum 12 feet for a 12 ft. x 12 ft. coverage area, or 20 feet for a 20 ft. x 20 ft. coverage area).

Beam Ceiling Design Criteria

The Series LFII (TY2234) Residential Pendent Sprinklers are UL and C-UL Listed for installation in residential occupancies with horizontal ceilings (i.e., slopes up to a 2 inch rise over a 12 inch run) with beams when installed in accordance with the following criteria:

General Information. The basic concept of this protection scheme is to locate the sprinklers on the underside of the beams, Ref. Figure 5, (not in the beam pockets); to identify the main beams that principally run in one direction as "primary beams"; and, to identify the beams that run principally perpendicular to the main beams, as may be present (or in some cases may be necessary for proper sprinkler protection), as "secondary beams".

Primary and Secondary Beam Types. Solid surface, solid or hollow core, combustible or non-combustible.

Primary and Secondary Beam Positioning. Directly attached to the underside of a combustible or non-combustible smooth ceiling at any elevation.

Primary Beam Cross-Section: Maximum depth of 14 inches and the maximum width is unlimited. The cross-sectional shape of the primary beam may be rectangular to circular.

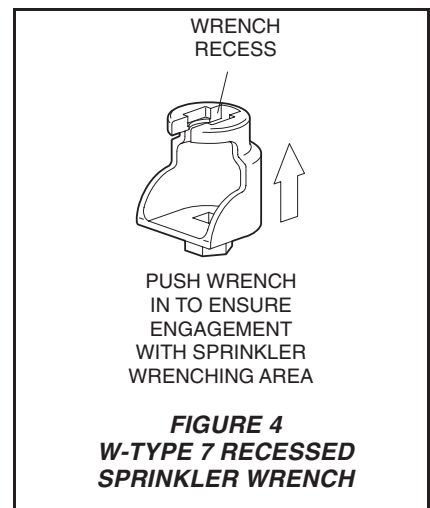
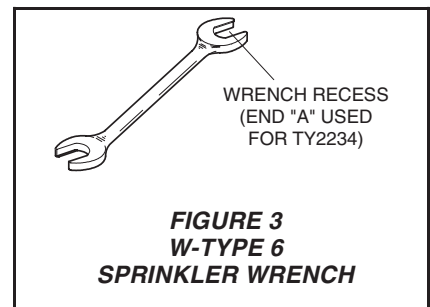
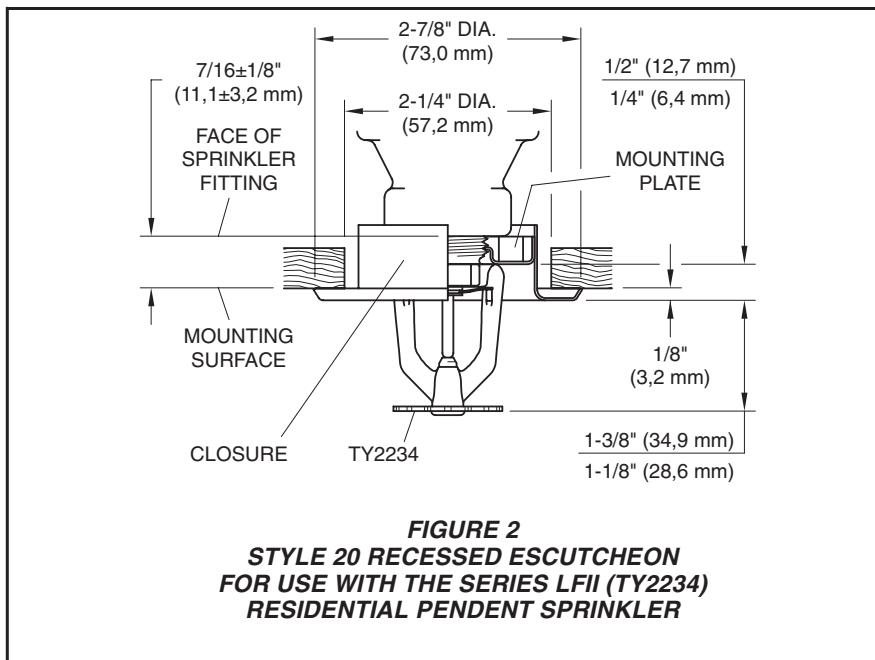
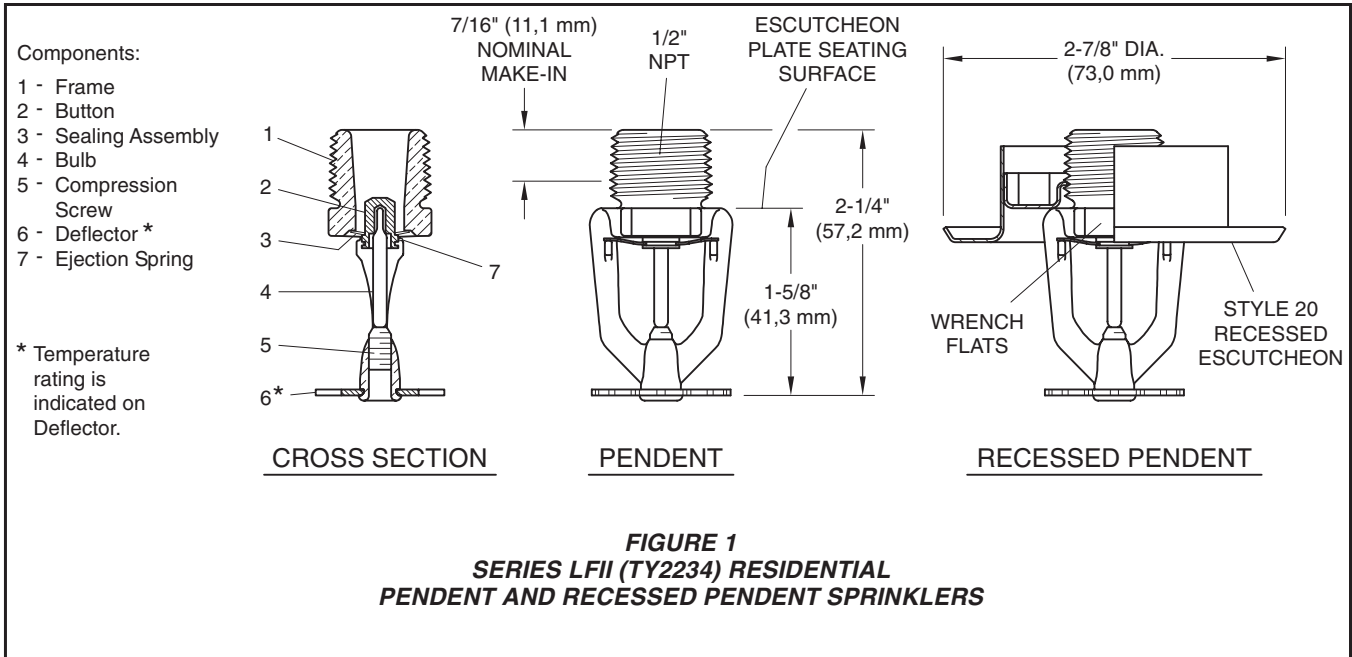

Secondary Beam Cross-Section. Maximum depth to be no greater than the primary beam and the maximum width is unlimited. The cross-sectional shape of the secondary beam may be rectangular to circular.

Primary Beam Spacing. The primary beams (Fig. 6A) are to be 3 ft. - 4 in. to 6 ft. from the compartment wall to center of the nearest beam and from center to center between beams.

Secondary Beam Spacing. The secondary beams principally run perpendicular to the primary beams. Secondary beams of a depth equal to

the primary beam must be placed so that the beam pockets created by the primary beams do not exceed 20 feet in length (Fig. 6B).

NOTE

When the beam pockets created by the primary beams exceed 20 feet in length, the installation will require the use of secondary beams as described above. Otherwise, secondary beams need not be present.

Secondary beams of a cross-sectional depth greater than one-quarter the depth of the primary beams are to be a minimum of 3 ft. - 4 in. from the

compartment wall to center of the nearest beam and from center to center between beams (Fig. 6C).

Secondary beams of a cross-sectional depth no greater than one-quarter the depth of the primary beams may be placed at any compartment wall to center of the nearest beam distance

and from any center to center distance between beams (Fig. 6C).

Lintels. Lintels over doorways exiting the compartment must be present. The minimum height for the lintels is 8 inches or no less than the depth of the Primary Beams, whichever is greater.

Sprinkler Types. Series LFII (TY2234), 155F and 175F, Pendent and Recessed Pendent Residential Sprinklers.

Sprinkler Coverage Area and Hydraulic Design. The sprinkler coverage areas and hydraulic design criteria as presented in the Table A for "Horizontal Ceilings" are to be applied.

Sprinkler Position. The deflector to bottom of primary beams for the Series LFII (TY2234) Pendent Sprinklers or Series LFII (TY2234) Recessed Pendent Sprinklers is to be 1-1/4 to 1-3/4 inches (Fig. 5A). The vertical centerline of the Series LFII (TY2234) Pendent Sprinklers is to be no greater than half the primary beam cross-sectional width plus 2 inches from the centerline of the primary beam (Fig 5B).

NOTES

Core drilling of beams to allow the installation of sprinkler drops requires consulting with a structural engineer.

Where core drilling is not permitted, the previously stated sprinkler position criteria for the Series LFII (TY2234) Pendent Sprinklers allows for the sprinkler drop to be placed adjacent to the primary beam.

Beam and Soffit Arrangements. A soffit is permitted to be placed around the perimeter of a compartment with the beam arrangement within the soffit area (Fig.7).

The cross-section of the soffit may be any size as long as it does not create an obstruction to water distribution per the obstruction rules of NFPA 13 for residential sprinklers.

When soffits are present, the previously provided 3 ft. - 4 in. to 6 ft. "compartment wall to adjacent beam" distance for the primary and secondary beams is to be measured from the face of the soffit as opposed to the compartment wall.

NOTE

Although the distance to the beams is measured from the face of the soffit, the sprinkler coverage area is to be measured from the compartment wall.

Installation

The Series LFII (TY2234) must be installed in accordance with the following instructions:

NOTES

Do not install any bulb type sprinkler if the bulb is cracked or there is a loss of liquid from the bulb. With the sprinkler held horizontally, a small air bubble should be present. The diameter of the air bubble is approximately 1/16 inch (1,6 mm).

A leak tight 1/2 inch NPT sprinkler joint should be obtained with a torque of 7 to 14 ft.lbs. (9,5 to 19,0 Nm). A maximum of 21 ft.lbs. (28,5 Nm) of torque is to be used to install sprinklers. Higher levels of torque may distort the sprinkler inlet with consequent leakage or impairment of the sprinkler.

Do not attempt to compensate for insufficient adjustment in an Escutcheon Plate by under- or over-tightening the Sprinkler. Readjust the position of the sprinkler fitting to suit.

The Series LFII Pendent Sprinklers must be installed in accordance with the following instructions.

Step 1. Pendent sprinklers are to be installed in the pendent position with the deflector parallel to the ceiling.

Step 2. With pipe thread sealant applied to the pipe threads, hand tighten the sprinkler into the sprinkler fitting.

Step 3. Tighten the sprinkler into the sprinkler fitting using only the W-Type 6 Sprinkler Wrench (Ref. Figure 3). With reference to Figure 1, the W-Type 6 Sprinkler Wrench is to be applied to the wrench flats.

The Series LFII Recessed Pendent Sprinklers must be installed in accordance with the following instructions.

Step A. Recessed pendent sprinklers are to be installed in the pendent position with the deflector parallel to the ceiling.

Step B. After installing the Style 20 Mounting Plate over the sprinkler threads and with pipe thread sealant applied to the pipe threads, hand tighten the sprinkler into the sprinkler fitting.

Step C. Tighten the sprinkler into the sprinkler fitting using only the W-Type 7 Recessed Sprinkler Wrench (Ref. Figure 4). With reference to Figure 1, the W-Type 7 Recessed Sprinkler Wrench is to be applied to the sprinkler wrench flats.

Step D. After the ceiling has been installed or the finish coat has been ap-

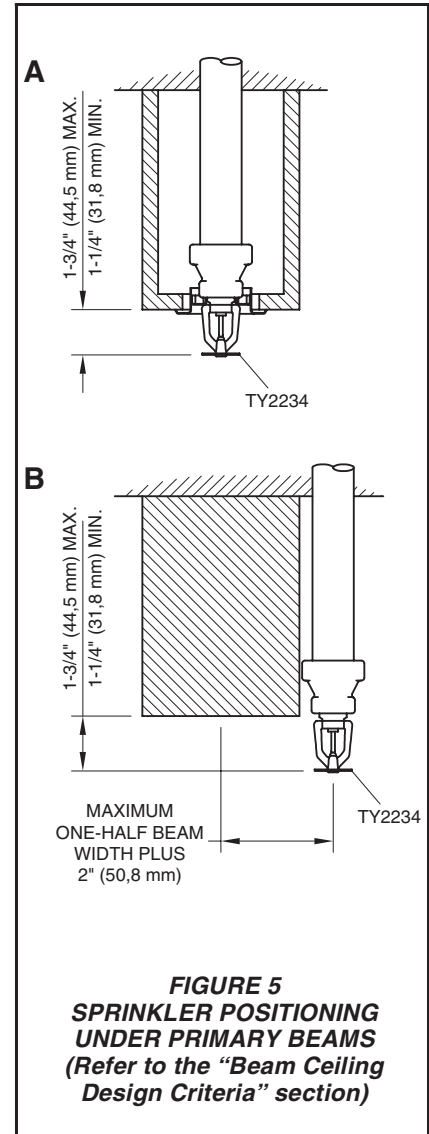

plied, slide on the Style 20 Closure over the Series LFII Sprinkler and push the Closure over the Mounting Plate until its flange comes in contact with the ceiling.

ALL FIGURES:
DISTANCES ARE
MEASURED TO
COMPARTMENT
WALL FACES AND
TO CENTERLINES
OF BEAMS

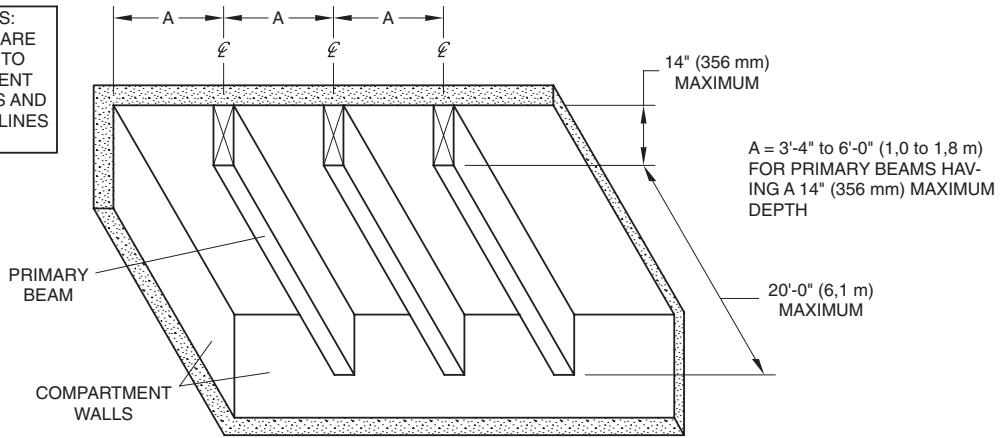

FIGURE 6A

PRIMARY BEAM SPANS UP TO 20'-0" (6,1 m)

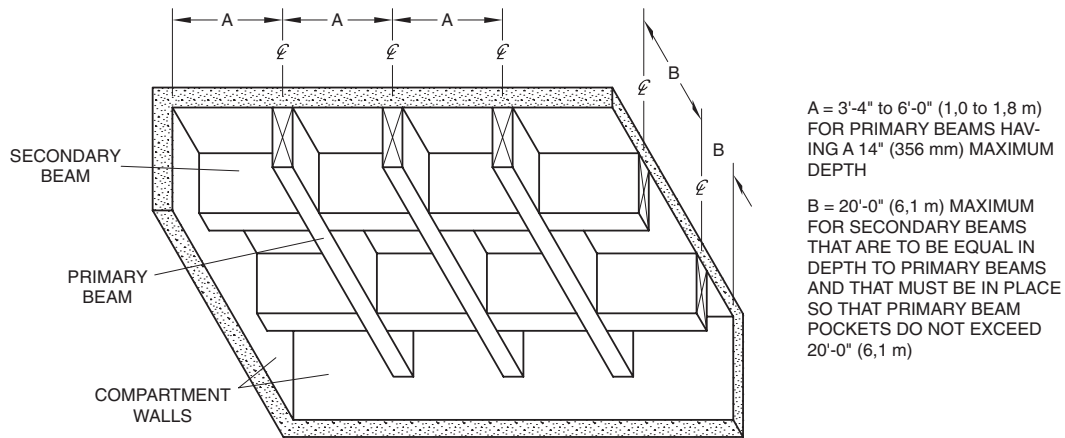

FIGURE 6B

PRIMARY BEAM SPANS GREATER THAN 20'-0" (6,1 m)

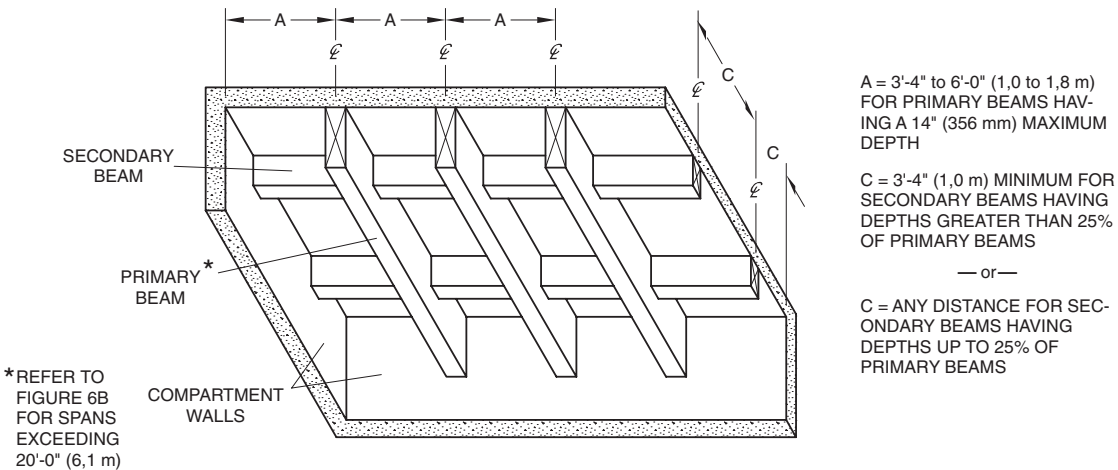
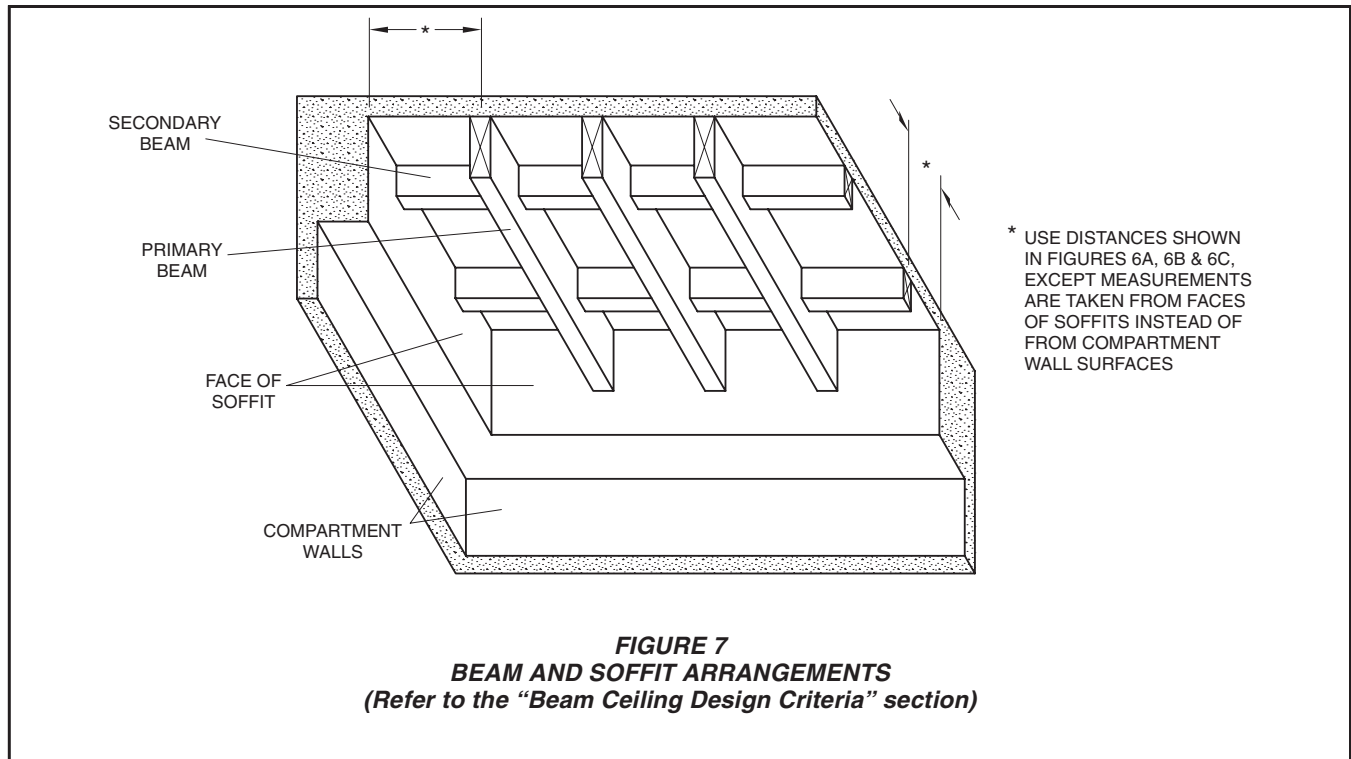

FIGURE 6C

COMBINATIONS OF PRIMARY AND SECONDARY BEAMS

FIGURE 6
BEAM ARRANGEMENTS
(Refer to the "Beam Ceiling Design Criteria" section)



Care and Maintenance

The Series LFII (TY2234) must be maintained and serviced in accordance with the following instructions:

NOTES

Absence of an Escutcheon Plate may delay the sprinkler operation in a fire situation.

Before closing a fire protection system main control valve for maintenance work on the fire protection system which it controls, permission to shut down the affected fire protection system must be obtained from the proper authorities and all personnel who may be affected by this action must be notified.

Sprinklers which are found to be leaking or exhibiting visible signs of corrosion must be replaced.

Automatic sprinklers must never be painted, plated, coated, or otherwise altered after leaving the factory. Modified sprinklers must be replaced. Sprinklers that have been exposed to corrosive products of combustion, but have not operated, should be replaced if they cannot be completely cleaned by wiping the sprinkler with a cloth or by brushing it with a soft bristle brush.

Care must be exercised to avoid dam-

age to the sprinklers - before, during, and after installation. Sprinklers damaged by dropping, striking, wrench twist/slippage, or the like, must be replaced. Also, replace any sprinkler that has a cracked bulb or that has lost liquid from its bulb. (Ref. Installation Section).

The owner is responsible for the inspection, testing, and maintenance of their fire protection system and devices in compliance with this document, as well as with the applicable standards of the National Fire Protection Association (e.g., NFPA 25), in addition to the standards of any other authorities having jurisdiction. The installing contractor or sprinkler manufacturer should be contacted relative to any questions.

NOTE

The owner must assure that the sprinklers are not used for hanging of any objects and that the sprinklers are only cleaned by means of gently dusting with a feather duster; otherwise, non-operation in the event of a fire or inadvertent operation may result.

It is recommended that automatic sprinkler systems be inspected, tested, and maintained by a qualified Inspection Service.

Limited Warranty

Products manufactured by Tyco Fire Products are warranted solely to the original Buyer for ten (10) years against defects in material and workmanship when paid for and properly installed and maintained under normal use and service. This warranty will expire ten (10) years from date of shipment by Tyco Fire Products. No warranty is given for products or components manufactured by companies not affiliated by ownership with Tyco Fire Products or for products and components which have been subject to misuse, improper installation, corrosion, or which have not been installed, maintained, modified or repaired in accordance with applicable Standards of the National Fire Protection Association, and/or the standards of any other Authorities Having Jurisdiction. Materials found by Tyco Fire Products to be defective shall be either repaired or replaced, at Tyco Fire Products' sole option. Tyco Fire Products neither assumes, nor authorizes any person to assume for it, any other obligation in connection with the sale of products or parts of products. Tyco Fire Products shall not be responsible for sprinkler system design errors or inaccurate or incomplete information supplied by Buyer or Buyer's representatives.

IN NO EVENT SHALL TYCO FIRE PRODUCTS BE LIABLE, IN CONTRACT, TORT, STRICT LIABILITY OR UNDER ANY OTHER LEGAL THEORY, FOR INCIDENTAL, INDIRECT, SPECIAL OR CONSEQUENTIAL DAMAGES, INCLUDING BUT NOT LIMITED TO LABOR CHARGES, REGARDLESS OF WHETHER TYCO FIRE PRODUCTS WAS INFORMED ABOUT THE POSSIBILITY OF SUCH DAMAGES, AND IN NO EVENT SHALL TYCO FIRE PRODUCTS' LIABILITY EXCEED AN AMOUNT EQUAL TO THE SALES PRICE.

THE FOREGOING WARRANTY IS MADE IN LIEU OF ANY AND ALL OTHER WARRANTIES EXPRESS OR IMPLIED, INCLUDING WARRANTIES OF MERCHANTABILITY AND FITNESS FOR A PARTICULAR PURPOSE.

Ordering Procedure

When placing an order, indicate the full product name. Contact your local distributor for availability..

Sprinkler Assembly:

Series LFII (TY2234), K=4.9, Residential Pendent Sprinkler with (specify) temperature rating and (specify) finish, P/N (specify).

155°F/68°C or Chrome Plated	P/N 51-201-9-155
155°F/68°C White Polyester	P/N 51-201-4-155
155°F/68°C Natural Brass	P/N 51-201-1-155
175°F/79°C or Chrome Plated	P/N 51-201-9-175
175°F/79°C White Polyester	P/N 51-201-4-175
175°F/79°C Natural Brass	P/N 51-201-1-175

Recessed Escutcheon:

Specify: Style 20 Recessed Escutcheon with (specify) finish, P/N (specify).

1/2" (15 mm) Style 20 Chrome Plated	P/N 56-705-9-010
1/2" (15 mm) Style 20 White Color Coated	P/N 56-705-4-010
1/2" (15 mm) Style 20 Bright Brass Coated	P/N 56-705-2-010

Sprinkler Wrench:

Specify: W-Type 6 Sprinkler Wrench, P/N 56-000-6-387.

Specify: W-Type 7 Sprinkler Wrench, P/N 56-850-4-001.

