

Series LFII Residential Flush Pendent Sprinklers 4.2 K-factor

General Description

The Series LFII (TY2284) Residential Flush Pendent Sprinklers are decorative, fast response, fusible solder sprinklers designed for use in residential occupancies such as homes, apartments, dormitories, and hotels. When aesthetics is the major consideration, the Series LFII (TY2284) should be the first choice.

The Series LFII are to be used in wet pipe residential sprinkler systems for one- and two-family dwellings and manufactured homes per NFPA 13D; wet pipe residential sprinkler systems for residential occupancies up to and including four stories in height per NFPA 13R; or, wet pipe sprinkler systems for the residential portions of any occupancy per NFPA 13.

The Series LFII (TY2284) has a 4.2 (60,5) K-factor that provides the required residential flow rates at reduced pressures, enabling smaller pipe sizes and water supply requirements.

The flush design of the Series LFII (TY2284) features a separable escutcheon providing 3/8 inch (9,5 mm) vertical adjustment. This adjustment reduces the accuracy to which the pipe drops to the sprinklers must be cut to help assure a perfect fit installation.

The Series LFII (TY2284) has been designed with heat sensitivity and water distribution characteristics proven to help in the control of residential fires and to improve the chance for occupants to escape or be evacuated.

WARNINGS

The Series LFII (TY2284) Residential Flush Pendent Sprinklers described herein must be installed and maintained in compliance with this document, as well as with the applicable standards of the National Fire Protection Association, in addition to the

standards of any other authorities having jurisdiction. Failure to do so may impair the integrity of these devices.

The owner is responsible for maintaining their fire protection system and devices in proper operating condition. The installing contractor or sprinkler manufacturer should be contacted relative to any questions.

Sprinkler/Model Identification Number

SIN TY2284

Technical Data

Approvals:
UL and C-UL Listed.

Maximum Working Pressure:
175 psi (12,1 bar)

Discharge Coefficient:
K = 4.2 GPM/psi^{1/2} (60,5 LPM/bar^{1/2})

Temperature Rating:
162°F/72°C

Vertical Adjustment:
3/8 inch (9,5 mm)

Finishes:
Sprinkler and Escutcheon:
White, Chrome, or Black

Physical Characteristics:
Body Bronze
Deflector Copper
Valve Cap Brass
Orifice Seal Copper
Heat Collectors Copper



Operation

The sprinkler assembly contains a small fusible solder element. When exposed to sufficient heat from a fire, the solder melts and enables the internal components of the sprinkler to fall away. At this point the sprinkler activates with the deflector dropping into its operated position (Reference Figure 1C), permitting water to flow.

Maximum Coverage Area (a) Ft. x Ft. (m x m)	Maximum Spacing Ft. (m)	Minimum Flow (b) and Residual Pressure For Horizontal Ceiling (Max. 2 Inch Rise for 12 Inch Run)	Minimum Flow (b) and Residual Pressure For Sloped Ceiling (Max. 8 Inch Rise for 12 Inch Run)	Minimum Flow (b) and Residual Pressure For Sloped Ceiling (Max. 8 Inch Rise for 12 Inch Run) Three sprinkler design when there are more than two sprinklers in a compartment.
		162°F/72°C	162°F/72°C	162°F/72°C
12 x 12 (3,7 x 3,7)	12 (3,7)	13 GPM (49,2 LPM) 9.6 psi (0,66 bar)	17 GPM (64,3 LPM) 16.4 psi (1,13 bar)	14 GPM (53,0 LPM) 11.1 psi (0,77 bar)
14 x 14 (4,3 x 4,3)	14 (4,3)	13 GPM (49,2 LPM) 9.6 psi (0,66 bar)	17 GPM (64,3 LPM) 16.4 psi (1,13 bar)	14 GPM (53,0 LPM) 11.1 psi (0,77 bar)
16 x 16 (4,9 x 4,9)	16 (4,9)	14 GPM (53,0 LPM) 11.1 psi (0,77 bar)	17 GPM (64,3 LPM) 16.4 psi (1,13 bar)	14 GPM (53,0 LPM) 11.1 psi (0,77 bar)
18 x 18 (5,5 x 5,5)	18 (5,5)	18 GPM (68,1 LPM) 18.4 psi (1,27 bar)	19 GPM (71,9 LPM) 20.5 psi (1,41 bar)	18 GPM (68,1 LPM) 18.4 psi (1,27 bar)
20 x 20 (6,1 x 6,1)	20 (6,1)	22 GPM (83,3 LPM) 27.4 psi (1,89 bar)	24 GPM (90,8 LPM) 32.7 psi (2,25 bar)	N/A

(a) For coverage area dimensions less than or between those indicated, it is necessary to use the minimum required flow for the next highest coverage area for which hydraulic design criteria are stated.

(b) Requirement is based on minimum flow in GPM (LPM) from each sprinkler. The associated residual pressures are calculated using the nominal K-factor. Refer to Hydraulic Design Criteria Section for details.

TABLE A
NFPA 13D AND NFPA 13R HYDRAULIC DESIGN CRITERIA
FOR THE SERIES LFII (TY2284)
RESIDENTIAL FLUSH PENDENT SPRINKLER

Design Criteria

The Series LFII (TY2284) Residential Flush Pendent Sprinklers are UL Listed and C-UL Listed for installation in accordance with the following criteria.

NOTE

When conditions exist that are outside the scope of the provided criteria, refer to the Residential Sprinkler Design Guide TFP490 for the manufacturer's recommendations that may be acceptable the local Authority Having Jurisdiction.

System Type. Only wet pipe systems may be utilized.

Hydraulic Design. The minimum required sprinkler flow rate for systems designed to NFPA 13D or NFPA 13R are given in Table A as a function of temperature rating and the maximum allowable coverage areas. The sprinkler flow rate is the minimum required discharge from each of the total number of "design sprinklers" as specified in NFPA 13D or NFPA 13R.

For systems designed to NFPA 13, the number of design sprinklers is to be the the four most hydraulically de-

manding sprinklers. The minimum required discharge from each of the four sprinklers is to be the greater of the following:

- The flow rates given in Table A for NFPA 13D and 13R as a function of temperature rating and the maximum allowable coverage area.
- A minimum discharge of 0.1 gpm/sq. ft. over the "design area" comprised of the four most hydraulically demanding sprinklers for the actual coverage areas being protected by the four sprinklers.

Obstruction To Water Distribution. Locations of sprinklers are to be in accordance with the obstruction rules of NFPA 13 for residential sprinklers.

Operational Sensitivity. The sprinklers are to be installed in the flush position per Figure 1 with the provided escutcheon.

Sprinkler Spacing. The minimum spacing between sprinklers is 8 feet (2,4 m). The maximum spacing between sprinklers cannot exceed the length of the coverage area (Ref. Table A) being hydraulically calculated (e.g., maximum 12 feet for a 12 ft. x 12 ft. coverage area, or 20 feet for a 20 ft. x 20 ft. coverage area).

Beam Ceiling Design Criteria

The Series LFII (TY2284) Residential Flush Pendent Sprinklers are UL and C-UL Listed for installation in residential occupancies with horizontal ceilings (i.e., slopes up to a 2 inch rise over a 12 inch run) with beams when installed in accordance with the following criteria:

General Information. The basic concept of this protection scheme is to locate the sprinklers on the underside of the beams, Ref. Figure 4, (not in the beam pockets); to identify the main beams that principally run in one direction as "primary beams"; and, to identify the beams that run principally perpendicular to the main beams, as may be present (or in some cases may be necessary for proper sprinkler protection), as "secondary beams".

Primary and Secondary Beam Types. Solid surface, solid or hollow core, combustible or non-combustible.

Primary and Secondary Beam Positioning. Directly attached to the underside of a combustible or non-combustible smooth ceiling at any elevation.

Primary Beam Cross-Section: Maxi-

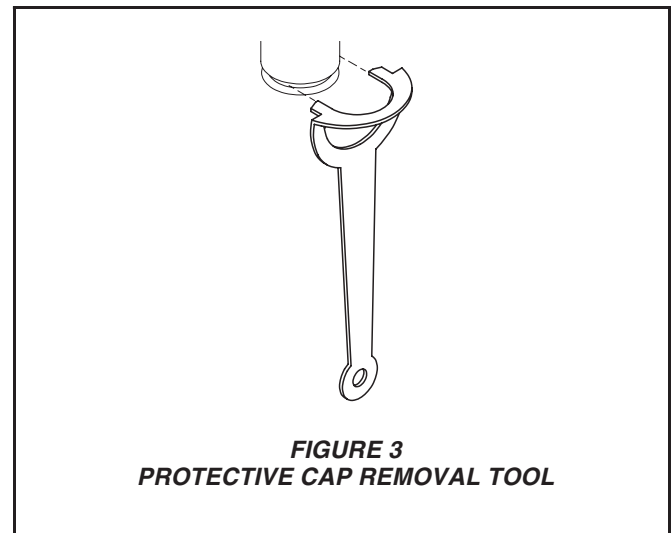
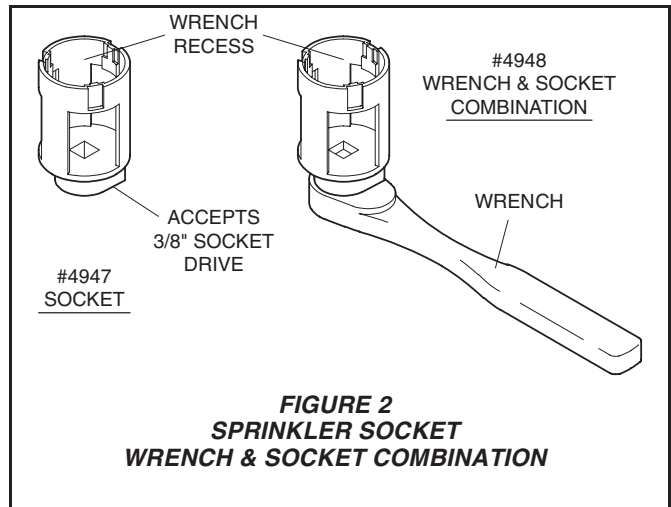
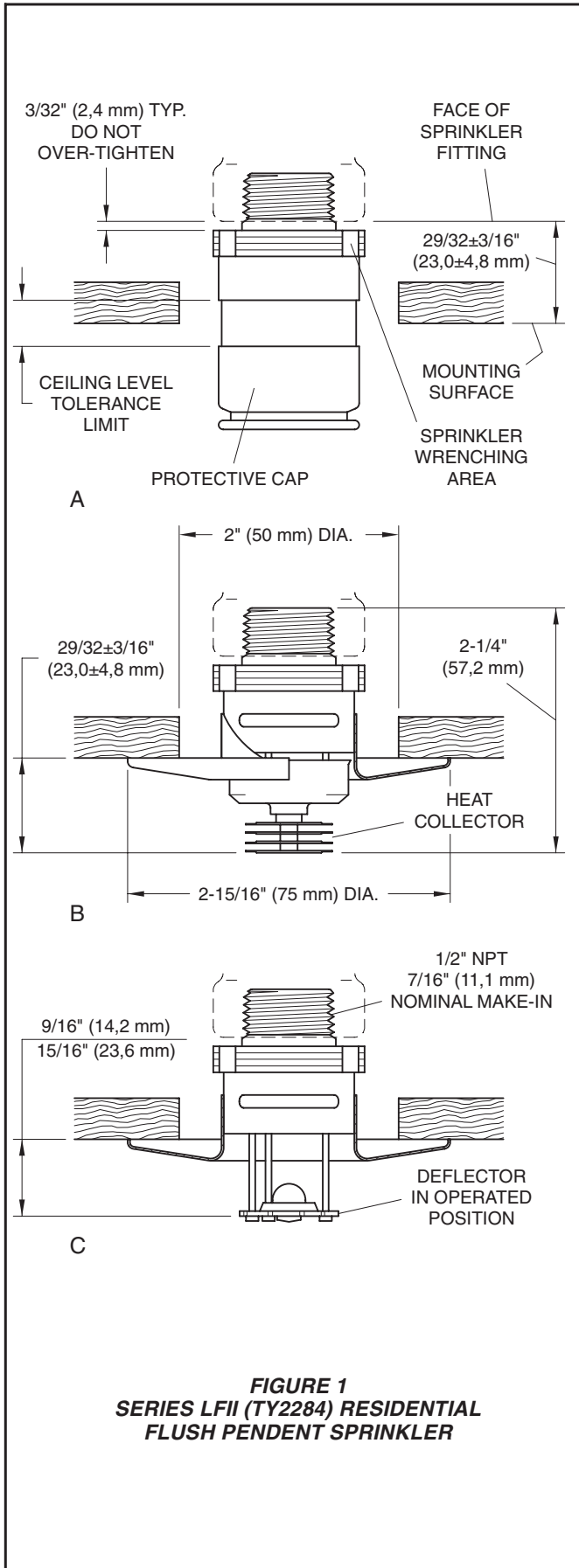

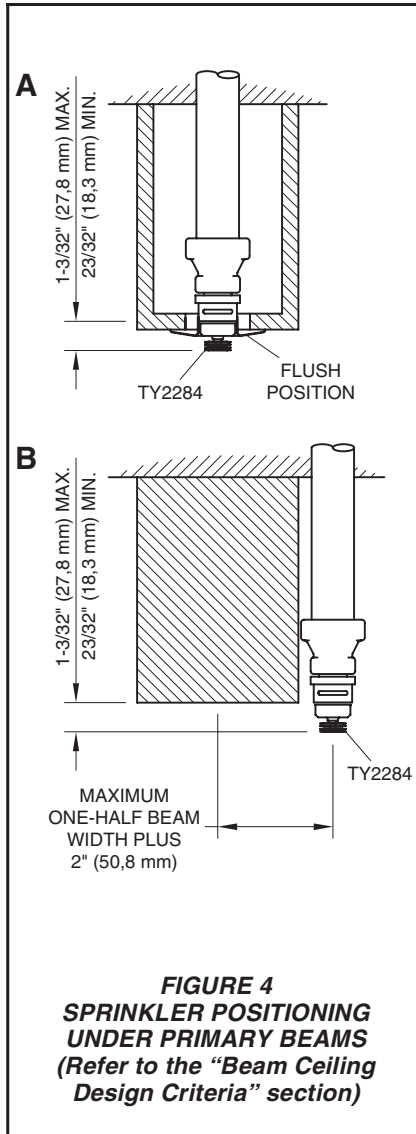

imum depth of 14 inches and the maximum width is unlimited. The cross-sectional shape of the primary beam may be rectangular to circular.

Secondary Beam Cross-Section. Maximum depth to be no greater than the primary beam and the maximum width is unlimited. The cross-sectional shape of the secondary beam may be rectangular to circular.

Primary Beam Spacing. The primary beams (Fig. 5A) are to be 3 ft. - 4 in. to 6 ft. from the compartment wall to center of the nearest beam and from center to center between beams.

Secondary Beam Spacing. The secondary beams principally run perpendicular to the primary beams.

Secondary beams of a depth equal to the primary beam must be placed so that the beam pockets created by the primary beams do not exceed 20 feet in length (Fig. 5B).

NOTE

When the beam pockets created by the primary beams exceed 20 feet in length, the installation will require the use of secondary beams as described above. Otherwise, secondary beams need not be present.

Secondary beams of a cross-sectional depth greater than one-quarter the depth of the primary beams are to be a minimum of 3 ft. - 4 in. from the compartment wall to center of the nearest beam and from center to center between beams (Fig. 5C).

Secondary beams of a cross-sectional depth no greater than one-quarter the depth of the primary beams may be placed at any compartment wall to center of the nearest beam distance and from any center to center distance between beams (Fig. 5C).

Lintels. Lintels over doorways exiting the compartment must be present. The minimum height for the lintels is 8 inches or no less than the depth of the Primary Beams, whichever is greater.

Sprinkler Types. Series LFII (TY2284), 162F, Flush Pendent Residential Sprinklers.

Sprinkler Coverage Area and Hydraulic Design. The sprinkler coverage areas and hydraulic design criteria as presented in the Table A for "Horizontal Ceilings" are to be applied.

Sprinkler Position. The bottom of heat collector to bottom of primary beams for the Series LFII (TY2284) Flush Pendent Sprinklers is to be 23/32 to 1-3/32 inches (Fig. 4A). The vertical centerline of the Series LFII (TY2284) Flush Pendent Sprinklers is to be no greater than half the primary beam cross-sectional width plus 2 inches from the centerline of the primary beam (Fig 4B).

NOTES

Core drilling of beams to allow the installation of sprinkler drops requires consulting with a structural engineer.

Where core drilling is not permitted, the previously stated sprinkler position criteria for the Series LFII (TY2234) Pendent Sprinklers allows for the sprinkler drop to be placed adjacent to the primary beam.

Beam and Soffit Arrangements. A soffit is permitted to be placed around the perimeter of a compartment with the beam arrangement within the soffit area (Fig.6).

The cross-section of the soffit may be any size as long as it does not create an obstruction to water distribution per the obstruction rules of NFPA 13 for residential sprinklers.

When soffits are present, the previously provided 3 ft.- 4 in. to 6 ft. "compartment wall to adjacent beam" distance for the primary and secondary beams is to be measured from the face of the soffit as opposed to the compartment wall.

NOTE

Although the distance to the beams is measured from the face of the soffit, the sprinkler coverage area is to be measured from the compartment wall.

ALL FIGURES:
DISTANCES ARE
MEASURED TO
COMPARTMENT
WALL FACES AND
TO CENTERLINES
OF BEAMS

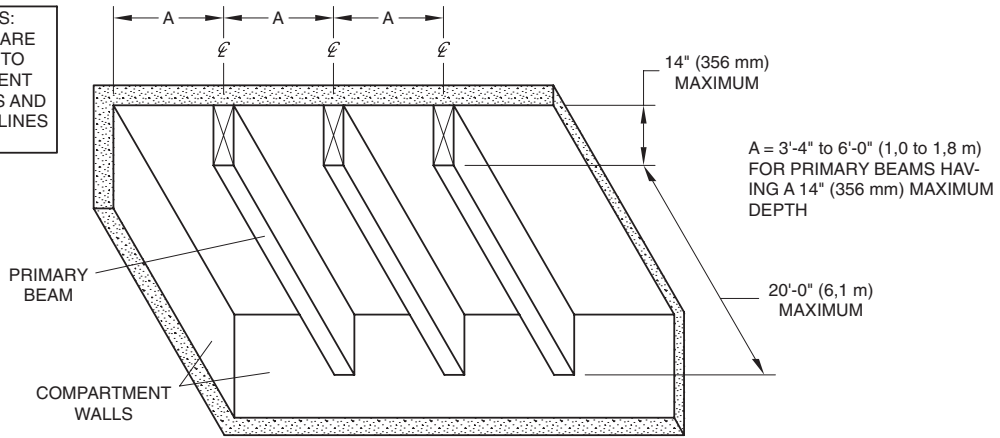

FIGURE 6A

PRIMARY BEAM SPANS UP TO 20'-0" (6,1 m)

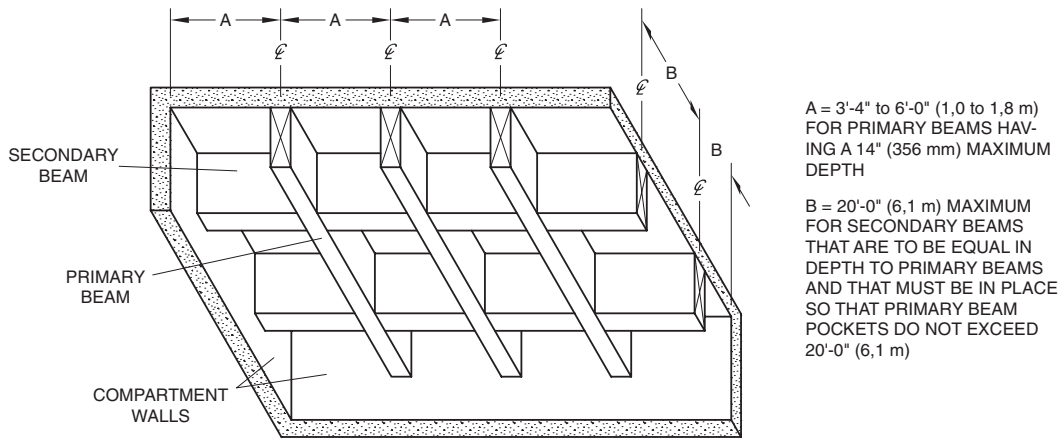

FIGURE 6B

PRIMARY BEAM SPANS GREATER THAN 20'-0" (6,1 m)

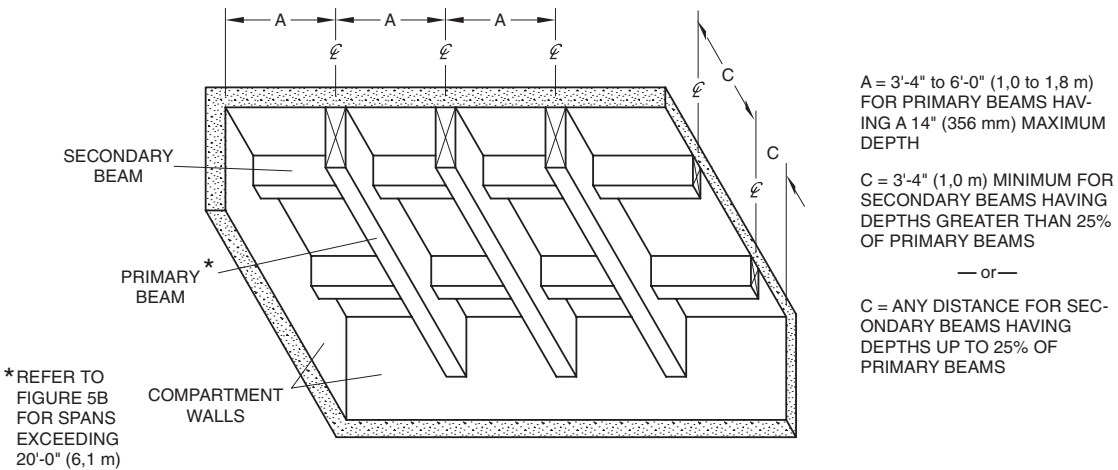
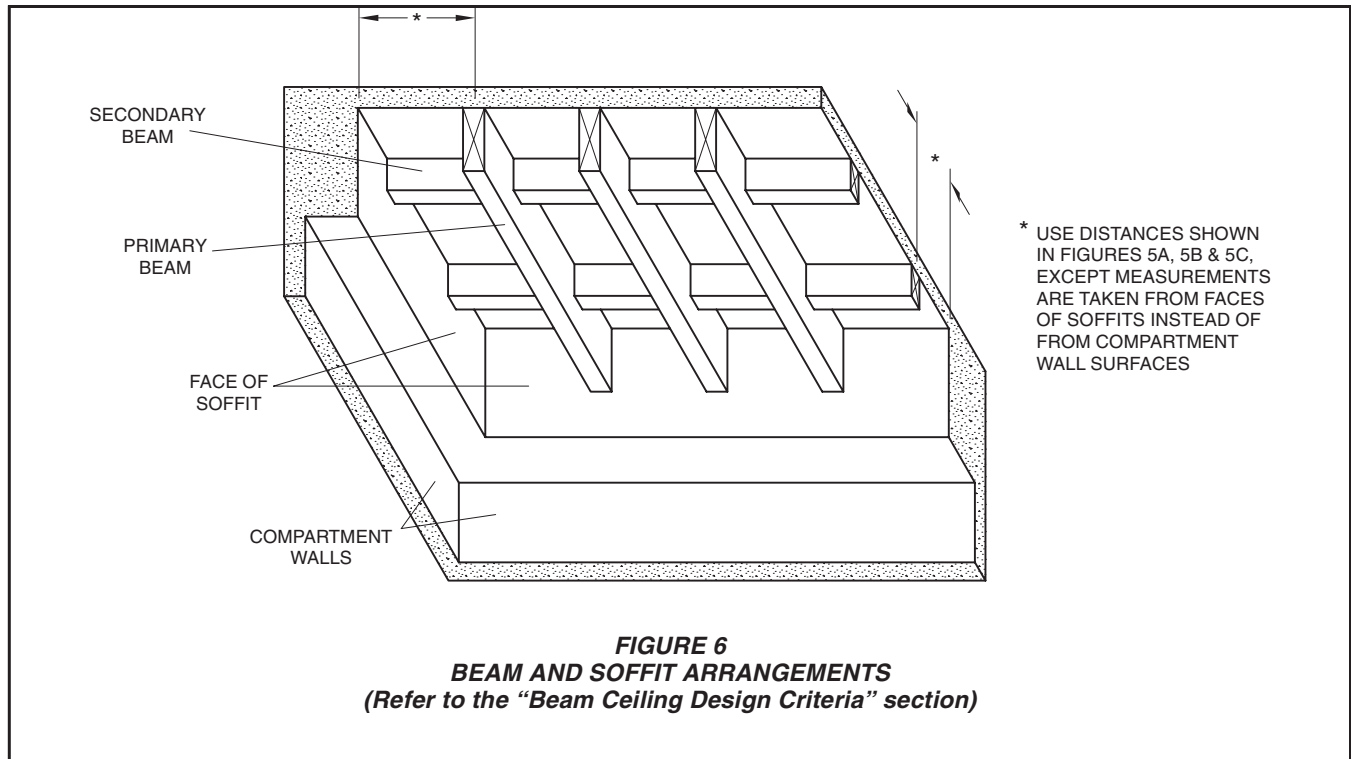

FIGURE 6C

COMBINATIONS OF PRIMARY AND SECONDARY BEAMS

* REFER TO
FIGURE 5B
FOR SPANS
EXCEEDING
20'-0" (6,1 m)

FIGURE 5
BEAM ARRANGEMENTS
(Refer to the "Beam Ceiling Design Criteria" section)



Installation

The Series LFII (TY2284) must be installed in accordance with the following instructions:

NOTES

The Protective Cap is to remain on the sprinkler during installation until the ceiling installation is complete. The Protective Cap must be removed to place the sprinkler in service.

A leak tight 1/2 inch NPT sprinkler joint should be obtained with a torque of 7 to 14 ft.lbs. (9,5 to 19,0 Nm). A maximum of 21 ft.lbs. (28,5 Nm) of torque is to be used to install sprinklers. Higher levels of torque may distort the sprinkler inlet with consequent leakage or impairment of the sprinkler.

Do not attempt to compensate for insufficient adjustment in an Escutcheon Plate by under- or over-tightening the Sprinkler. Readjust the position of the sprinkler fitting to suit.

Each sprinkler must be inspected before installation. Do not use any sprinkler that exhibits any deformations or cracks, including cracks on the protective cap.

Step 1. The Sprinkler must be installed only in the pendent position and with the Sprinkler waterway centerline perpendicular to the mounting surface.

Step 2. Install the sprinkler fitting so that the distance from the face of the

fitting to the mounting surface will be nominally 29/32 inches (23,0 mm) as shown in Figure 1A.

Step 3. With pipe thread sealant applied to the pipe threads, hand tighten the Sprinkler into the sprinkler fitting.

Step 4. Wrench tighten the Sprinkler using only the Sprinkler Socket or Wrench & Socket Combination (Ref. Figure 2). The wrench recess of the Socket is to be applied to the sprinkler wrenching area (Ref. Figure 1A).

Step 5. Use the "ceiling level tolerance limit" indicator on the Protective Cap to check for proper installation height. Relocate the sprinkler fitting as necessary. If desired the Protective Cap may also be used to locate the center of the clearance hole by gently pushing the ceiling material against the center point of the Cap.

Step 6. After the ceiling has been completed with the 2 inch (50 mm) diameter clearance hole, use the Protective Cap Removal Tool (Ref. Figure 3) to remove the Protective Cap and then push on the Escutcheon until its flange just comes in contact with the ceiling. Do not continue to push the Escutcheon such that it lifts a ceiling panel out of its normal position. If the Escutcheon cannot be engaged with the Sprinkler, or the Escutcheon cannot be engaged sufficiently to contact the ceiling, relocate the sprinkler fitting as necessary.

Care and Maintenance

The Series LFII (TY2284) must be maintained and serviced in accordance with the following instructions:

NOTES

Absence of an Escutcheon Plate may delay the time to sprinkler operation in a fire situation.

Before closing a fire protection system main control valve for maintenance work on the fire protection system which it controls, permission to shut down the affected fire protection system must be obtained from the proper authorities and all personnel who may be affected by this action must be notified.

Sprinklers which are found to be leaking or exhibiting visible signs of corrosion must be replaced.

Automatic sprinklers must never be painted, plated, coated, or otherwise altered after leaving the factory. Modified or over heated sprinklers must be replaced.

Care must be exercised to avoid damage - before, during, and after installation. Sprinklers damaged by dropping, striking, wrench twist/slippage, or the like, must be replaced.

The owner is responsible for the in-

pection, testing, and maintenance of their fire protection system and devices in compliance with this document, as well as with the applicable standards of the National Fire Protection Association (e.g., NFPA 25), in addition to the standards of any other authorities having jurisdiction. The installing contractor or sprinkler manufacturer should be contacted relative to any questions.

NOTE

The owner must assure that the sprinklers are not used for hanging of any objects and that the sprinklers are only cleaned by means of gently dusting with a feather duster; otherwise, non-operation in the event of a fire or inadvertent operation may result.

It is recommended that automatic sprinkler systems be inspected, tested, and maintained by a qualified Inspection Service.

Limited Warranty

Products manufactured by Tyco Fire Products are warranted solely to the original Buyer for ten (10) years against defects in material and workmanship when paid for and properly installed and maintained under normal use and service. This warranty will expire ten (10) years from date of shipment by Tyco Fire Products. No warranty is given for products or components manufactured by companies not affiliated by ownership with Tyco Fire Products or for products and components which have been subject to misuse, improper installation, corrosion, or which have not been installed, maintained, modified or repaired in accordance with applicable Standards of the National Fire Protection Association, and/or the standards of any other Authorities Having Jurisdiction. Materials found by Tyco Fire Products to be defective shall be either repaired or replaced, at Tyco Fire Products' sole option. Tyco Fire Products neither assumes, nor authorizes any person to assume for it, any other obligation in connection with the sale of products or parts of products. Tyco Fire Products shall not be responsible for sprinkler system design errors or inaccurate or incomplete information supplied by Buyer or Buyer's representatives.

IN NO EVENT SHALL TYCO FIRE PRODUCTS BE LIABLE, IN CONTRACT, TORT, STRICT LIABILITY OR UNDER ANY OTHER LEGAL THEORY, FOR INCIDENTAL, INDIRECT, SPECIAL OR CONSEQUENTIAL DAMAGES, INCLUDING BUT NOT LIMITED TO LABOR CHARGES, REGARDLESS OF WHETHER TYCO FIRE PRODUCTS WAS INFORMED ABOUT THE POSSIBILITY OF SUCH DAMAGES, AND IN NO EVENT SHALL TYCO FIRE PRODUCTS' LIABILITY EXCEED AN AMOUNT EQUAL TO THE SALES PRICE.

THE FOREGOING WARRANTY IS MADE IN LIEU OF ANY AND ALL OTHER WARRANTIES EXPRESS OR IMPLIED, INCLUDING WARRANTIES OF MERCHANTABILITY AND FITNESS FOR A PARTICULAR PURPOSE.

Ordering Procedure

When placing an order, indicate the full product name. Contact your local distributor for availability..

Sprinkler Assembly:

Series LFII (TY2284), K=4.2, Residential Flush Pendent Sprinkler without Escutcheon and having a (specify) finish, P/N (specify).

Chrome	51-123-0-162
White	51-123-4-162
Black	51-123-6-162

Escutcheon:

Escutcheon for Series LFII (TY2284), K=4.2, Residential Flush Pendent Sprinkler with (specify) finish, P/N (specify).

Chrome	56-123-9-001
White	56-123-4-001
Black	56-123-6-001

Accessories:

Socket for Series LFII (TY2284) Residential Flush Pendent Sprinkler, P/N 56-000-4-947.

Wrench & Socket for Series LFII (TY2284) Residential Flush Pendent Sprinkler, P/N 56-000-4-948.

Protective Cap Removal Tool for Series LFII (TY2284) Residential Flush Pendent Sprinkler, P/N 56-000-4-300.

